

Magnetic Stop, black-6/8/10

Magnetanschlag, schwarz - 6/8/10 kaufen Jetzt sparen in unserem Onlineshop !

Product number ZB-2015

Weight 0.076kg

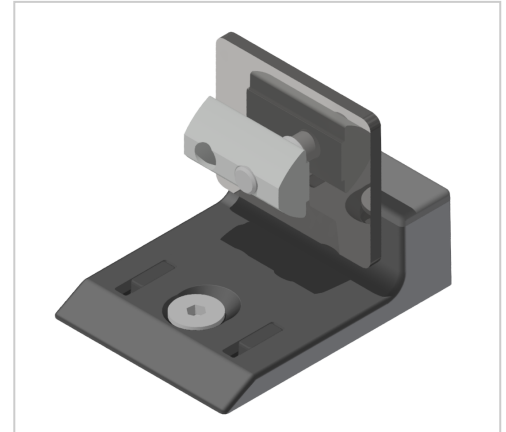

Product description

The magnetic stop serves to guard and as a stop for swivel doors.

Product properties

Compatible with Bosch

Part type Door stops, Locks

Colour black

Series Series 60-10, Series 45-10, Series 50-10, Series 40-10, Series 30 8, Series 20-6

More images

