

Clamp-Block PA, black-10

Klemmblock PA, schwarz-10 kaufen ? Jetzt sparen in unserem Onlineshop ?!

Product number ZB-3139

Weight 0.008kg

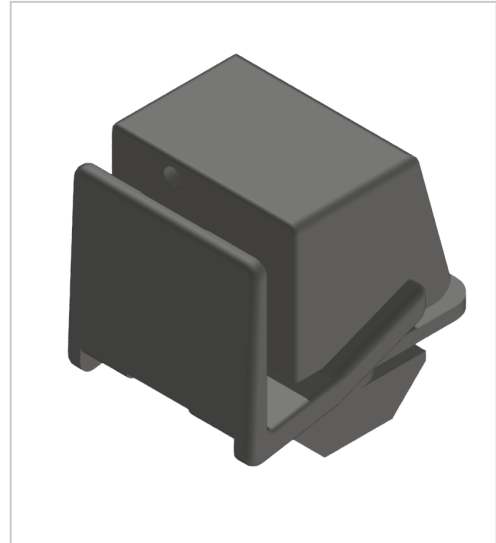

Product description

Terminal blocks enable safe and stable attachment of various Fächenelemente of constructions. These are subsequently used in assemblies. By turning into the profile the position can be freely selected. By attachable spacers of different thicknesses can be used.

Product properties

Compatible with Bosch

Colour black

Series Series 60-10, Series 45-10, Series 50-10, Series 40-10

Part type Clamp block

More images

